

# Model 7680

## Postal Weight Classifier



*NCI Model 7680 shown with standard flat weight platter*

- **Capacity**– 150 lb or 75 kg
- **Construction**– Stainless steel weight platter. Painted mild steel base enclosure.
- **Display**– 1/2" high, 7 digit LCD
- **Power**– AC power
- **Operator Keys**– Zero and Unit

# Model 7680 Postal Weight Classifier

## Features

The NCI Model 7680 Postal Weight Classifier with Quartzell® technology provides the most repeatable and accurate weight measurement for mail manifesting or any application requiring high resolution.

**Accurate and Reliable**— Quartzell® transducers provide the highest repeatability for consistent weight measurement

**Fast Digital Response**— The inherent digital signal allows the scale to weigh faster, improving throughput especially in weight ranges that are critical for flats and small parcels

**Internal Display**— 1/2" high (12.7 mm), 7 digit LCD

**Construction**— Stainless steel weigh platter. Painted mild steel base enclosure.

**Controls**— ZERO: With AZT or push button to re-establish zero reference. UNITS: Allows unit switching, or a real-time view of internal setting.

**Field Calibration**— Alternate span points can simplify field calibration by using less than full capacity weights

**Units Switching**— Switch between decimal pounds and pounds/ounces, decimal pounds and kilograms, or pounds/ounces and kilograms

**RS-232 Cable**— Includes DB-9 pin female connector allows you to connect to a PC

**Emulation Protocols**— Standard NCI default with field configurable settings of AS350D and PS6L. This allows you to select compatible scale communication settings or scale drivers during field installation when interfacing with shipping software programs or host devices.

**Metrologic Configurations**— Set-up scale to display weight as multi-range, multi-interval or high resolution

## Specifications

**Capacity**— Capacity: 150 lb or 75 kg

<u>Classifier Mode</u>	<u>Scale Mode</u>	<u>Kg Mode</u>
0-10 lb x 0.1 oz	0-10 lb x 0.005 lb	0-5 kg x 0.005 kg
10-150 lb x 0.5 oz	10-150 lb x 0.02 lb	5-75 kg x 0.01 kg

*Note: Standard configuration as postal weight classifier. Can be reconfigured for normal scale rounding during setup.*

**Dimensions**— 18" L x 18" W x 4.6" H  
457 mm (L) x 457 mm (W) x 117 mm (H)

**Power**— 120 VAC (+10% -15%), 60 Hz, standard 3-wire ground

**Operating Environment**—  
Temperature: 42° F to 104° F (5° C to 40° C)

**Input/Output**— RS-232, bi-directional, configurable 2400 – 9600 baud. Transmits weight and scale status whenever a "W" command is sent.

**Shipping Weight**— 45 lb (21 kg), standard configuration  
60 lb (28 kg), ball-top weight platter

## Options

**Ball-Top Weigh Platter**— Simplifies transport of all parcels. Ideal for conveyor lines.

**Customer Display**— 7 digit LCD housed in a molded plastic enclosure with a 7 ft (2 m) cable

**Display Post**— 12" (30.5 cm) post for customer display

**International Power Supply**— 230 VAC, 50 Hz power supply. End of cable terminated with a universal connector.

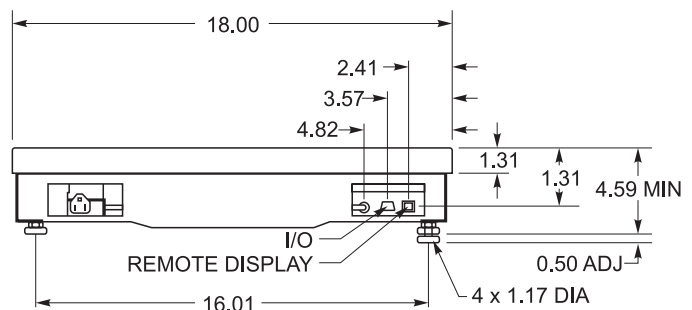

a division of Avery Weigh-Tronix, LLC

### Brecknell

1000 Armstrong Dr., Fairmont, MN 56031  
Toll free: 800-637-0529, Tel: 507-238-8702  
Fax: 507-238-8271  
e-mail: sales@brecknell scales.com  
www.brecknell scales.com

